

# Instructions

for your

## BODY BIKE Indoor Cycle



**BODY BIKE** Basic  
**BODY BIKE** Classic  
**BODY BIKE** Classic Stainless Steel



## TABLE OF CONTENTS

Equipment required	2
Introduction	3
Specifications	4
General information	5
Warranty	5
<b>Assembly</b>	
Unpacking	7
Handlebar	8
Bottom frame	8
Saddle	9
Pedals	9
<b>Maintenance</b>	
Cleaning	11
Adjustment handle	12
Cleaning the posts	13
Poly-V belt	14
Replacing the brake block	15
<b>Trouble-shooter</b>	17
<b>Index</b>	17

## EQUIPMENT REQUIRED

### Unpacking

Drill bit  
Drill

### Bottom Frame

6 mm Allen wrench  
13 mm wrench

### Saddle

14 mm wrench

### Pedals

15mm pedal wrench  
Grease

### Cleaning

Tissue paper or cloth  
Spray bottle with water  
Soap (only washing-up liquid)  
Vaseline oil

### Post Cleaning

Cloth  
Vaseline oil

### Adjustment Handle

5mm Allen Wrench  
Screwdriver  
Steel brush  
Grease  
Brush

### Poly-V Belt

10 mm Allen wrench  
19 mm wrench  
Screwdriver  
Measuring device

### Brake block

8 mm wrench

## INTRODUCTION

This manual provides information on the assembly and maintenance of the BODY BIKE indoor cycle. The manual is intended for the owners and service people responsible for cleaning and maintenance.

Before assembling the cycle, please read the manual and prepare the correct tools, see equipment required page 2. When assembling the cycle, we recommend that you follow the manual step by step.

Maintaining the cycle is very important. In the manual you will find clear instructions on how to maintain the cycle.

Over time it will be necessary to replace worn-out parts. You will find a detailed description and exploded drawings of BODY BIKE's spare parts on our website [www.body-bike.com](http://www.body-bike.com). When ordering spare parts from the local BODY BIKE distributor, please refer to the item number (P/N no.) in order to make sure you will receive the correct spare part.

We recommend that you order original parts, accessories and materials necessary for the maintenance of the cycle at your local BODY BIKE distributor. For further information on accessories, please check our website [www.body-bike.com](http://www.body-bike.com).

*We wish you the best of luck with your  
BODY BIKE indoor cycle*



## SPECIFICATIONS

### **Manufacturer:**

BODY BIKE International A/S  
Pier 6 Nord  
DK-9900 Frederikshavn  
Denmark  
Tlf: +45 9843 9696  
Fax: +45 9843 9688  
www.body-bike.com

### **Product description:**

Indoor cycle

### **Length, Width, Height:**

Assembled size:  
105cm, 60cm, 100cm  
Packed size (5 cycles):  
120cm, 80cm, 114cm

### **Weight:**

Assembled: 65 kg  
Packed weight(5 cycles): 350 kg

### **Patent held for:**

Crank system

### **Maximum user weight**

150 kg (Please note that the max. pedal load may be lower)

### **Materials**

#### **Basic version:**

Cast iron  
Steel and chrome  
Plastic (ABS) covers  
Quality bearings  
Frame: Robot-welded, powder coated and hardened

#### **Classic version:**

Cast iron  
Stainless steel  
Plastic (ABS) covers  
High quality bearings  
Frame: Robot-welded, fully galvanized, powder coated and hardened

#### **Classic Stainless Steel version:**

Cast iron  
Stainless steel  
Plastic (ABS) covers  
High quality bearings  
Frame: Robot-welded, stainless steel, electro galvanized.



## GENERAL INFORMATION

Wipe off the cycles after EVERY use

ALWAYS loosen all handles and release tension after use

The rubber feet should always be adjusted to ensure that the cycle is in level

Every other year the rubber feet should be replaced as the rubber hardens and becomes unable to absorb the impact

Tighten up the pedals every 14 days or every month to avoid them getting loose or breaking off.

Pedals should be changed once a year

DO NOT perform stretch exercises on the cycle, pedals or up against the cycle, except against the stretch plate at the rear end of the cycle

DO NOT switch the front or seat post from one cycle to another

DO NOT lift the cycle by the saddle

## WARRANTY

A two-year warranty for the Danish manufactured BODY BIKE Indoor Cycle:

A two-year warranty against manufacturing defects, excluding normal wear and tear, is given for the flywheel and pulley. A three-year warranty is given on the crank and the pedal arms, and a five year warranty is given against frame breakage.

Consumable items (such as the poly V-belt, brake pad, handlebar rubber, saddle and pedals, etc.) which are subject to continuous wear and tear, are not covered by a warranty.

There is currently no warranty applying to the pedals.

The warranty only applies to cycles equipped with original BODY BIKE spare parts. All warranties are cancelled if the cycle has been modified or in any way not used as intended.

**ALWAYS RELEASE TENSION AFTER USE**

# ASSEMBLY

Unpacking	7
Handlebar	8
Bottom frame	8
Saddle	9
Pedals	9

## **UNPACKING THE PALLET**

- 1) Begin with opening the top of the box.
- 2) Remove all the unmounted parts.
- 3) Flatten the box on the floor next to the pallet.
- 4) Loosen the two screws mounting the first cycle to the pallet.
- 5) Lift the cycle off the pallet and place it on the flattened box to spare your floor from getting marks.

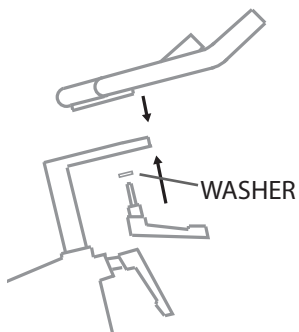

Figure 1

**Please note**  
**Do not over-tighten the nuts.**  
**They should only be hand tight.**

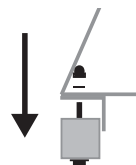

Figure 3

## HANDLEBAR

- 1: Place the handlebar on top of the front post.
- 2: Screw an adjustment handle (size 32mm) clockwise into the socket from underneath the post, see figure 1. Fix the handlebar completely to the front post by tightening the adjustment screw on the side of the handlebar.

## BOTTOM FRAME

A fixing tool can be bought at BODY BIKE International A/S to ease the mounting of the bottom frame.

1. Arrange the bottom frames parallel on the floor next to the cycle with the correct mounting distance between them, see figure 2. On the front bottom frame, the transport wheels should point forward.
2. Take hold of the front post and seat post and lift the cycle onto the bottom frames, see figure 2. Ensure that the holes in the frame match the holes in the bottom frames.
- 3: Put on the spring lock washer and the cap nut and tighten by using a 13 mm wrench, see figure 3.
- 4: Unscrew the rubber feet a little. Place the cycle in the correct position. Turn them up and down until the cycle stands properly and it is in level.

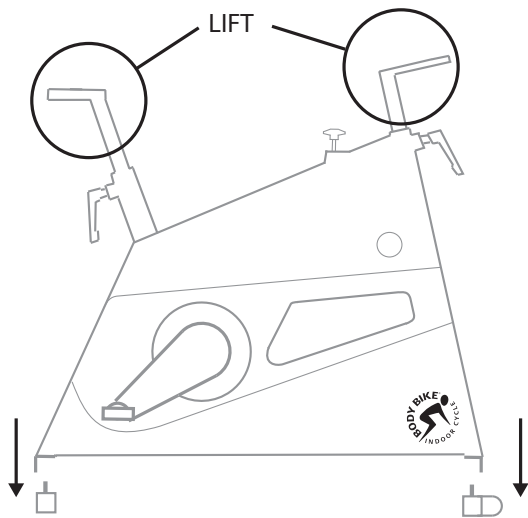

Figure 2

## SADDLE

1: Place the saddle in the track on the seat post.

2: Secure the saddle with the remaining adjustment handle, see figure 4.

To fasten the saddle to the adaptor and adjust the tilt of the saddle use a 14 mm wrench on the bolt marked with an A on figure 4.

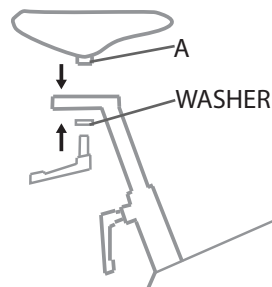

Figure 4

## PEDALS

1: Place the right pedal arm with the socket pointing upwards, see figure 5.

2: Put maximum resistance on the brake, so the pedalarm is unable to rotate, see figure 6.

### Please note

- the pedals are marked with **R** for Right and **L** for Left side.
- the pedals should always be screwed on in the direction of the handlebar, see figure 7.
- make sure that the hole in the pedal arm is greased when mounting the pedal.
- start mounting the pedal by hand as tools will tighten the pedal at a wrong angle.

3: After tightening by hand, use a 15mm pedal wrench to tighten the pedal completely (45N/4,5kg).

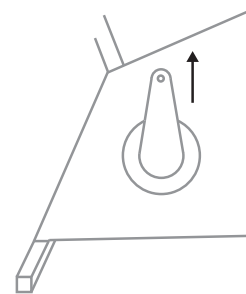

Figure 5

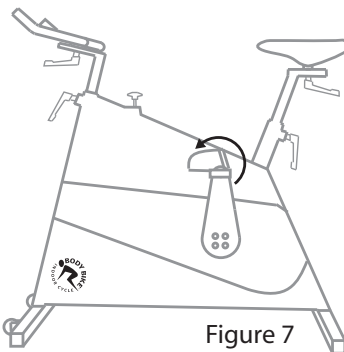
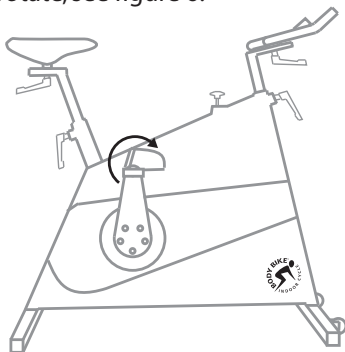

Figure 7

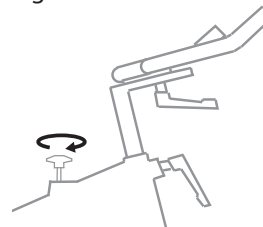

Figure 6

# MAINTENANCE

Cleaning	(After every use)	11
Adjustment handles	(Every 3 months)	12
Cleaning the posts	(Every other week)	13
Poly-V belt	(When necessary)	14
Replacing the brake block	(When necessary)	15

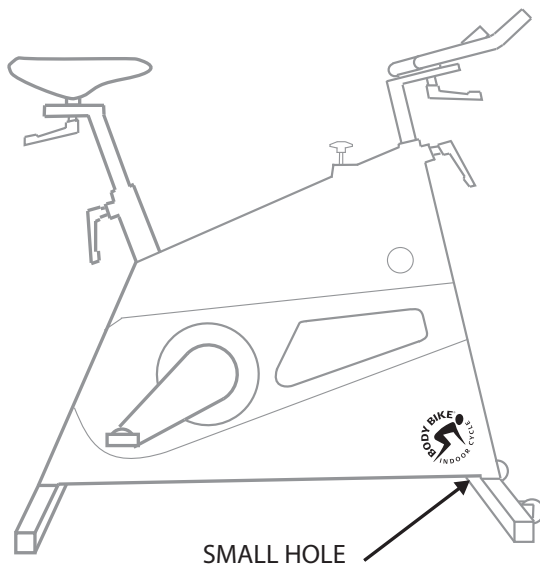

Figure 8

## CLEANING

After each workout, wipe the cycle down with tissue paper.

If the cycle is covered in sweat or dirt, use water in a spray bottle and if necessary a tissue with some washing-up liquid. Remember handlebar and saddle.

### **NEVER use alcohol or chemicals**

To make the cycle look its best, use a cloth with a little vaseline oil on all parts except the handlebar and saddle.

Always make sure that the small hole by the front bottom frame is not blocked and allows water and sweat to exit the frame, see figure 8.

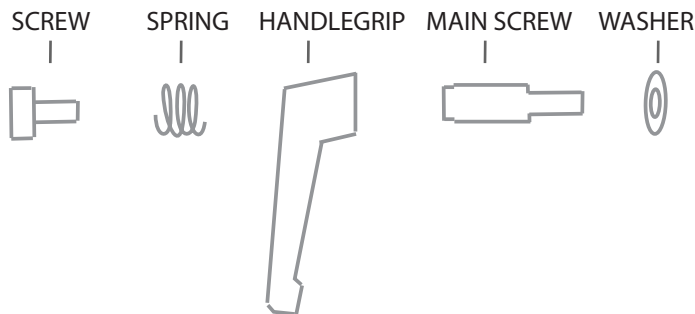

**Please note**  
Never use a tool when  
tightening the adjustment  
handle on the cycle.

**By pulling the handle it can  
be turned freely.**

Figure 9

## ADJUSTMENT HANDLE

Every 3 months the handles need cleaning and grease to protect the parts from sweat, dust, dirt and water.

1: Remove the adjustment handle and disassemble the handle completely into a screw, a spring, a handle grip, a main screw and a brass washer, see figure 9.

2: Clean all the parts thoroughly one by one using a steel brush. If the residue is extreme, a sharp object can be used, for example a screwdriver.

3: Lubricate the internal parts with grease before

reassembling the handle. Remember to lubricate inside the handle as well.

4: Reassemble the handle by inserting the main screw in the handle grip.

5: The spring is inserted into the top of the handle and fixed in place with the remaining screw.

6: Tighten with a 5mm Allen wrench.

7: Add grease to the main screw before mounting it on the cycle.

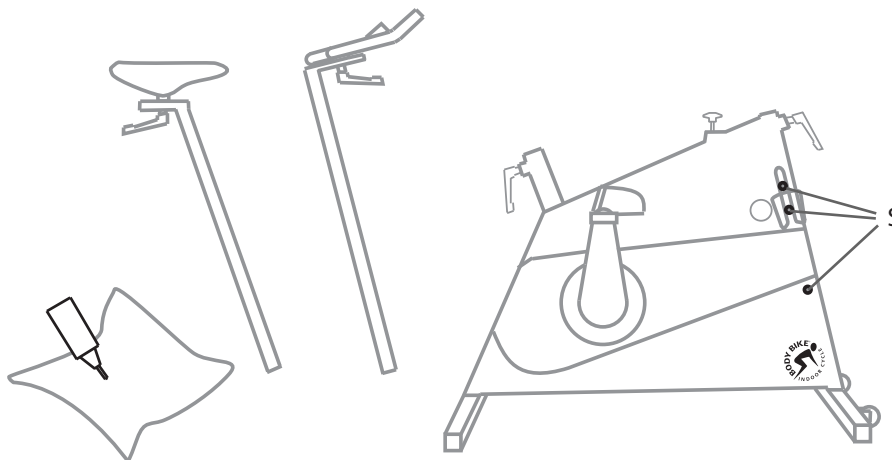

Figure 10

### CLEANING THE POSTS

Every other week the posts need cleaning to protect them from sweat etc.

1: Pull out the seat post and the front post and wipe them clean with an oily cloth, see figure 10.

If there is a slight sideways play in the front post you can adjust it on both sides of the cycle with the screws marked with an S on figure 10. This adjustment has to be very subtle in order for the post still to be able to move up and down.

**Please note:**

**The posts should be cleaned every other week to keep them in good condition**

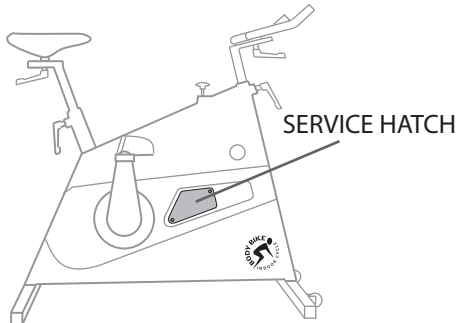

Figure 11

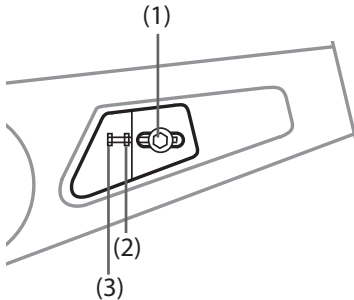

Figure 12

## POLY-V BELT

If the belt does not catch hold of the flywheel, it is time for it to be tightened.

- 1: Remove the service hatch on both sides of the cycle with a screwdriver, see figure 11.
- 2: Loosen the bolts (1) on both sides of the cycle with a 19 mm wrench, see figure 12
- 3: Loosen the nuts (2) on the counter bolt on both sides of the cycle with a 10 mm wrench, see figure 12.
- 4: Use a wrench to tighten the counter bolts (3). On the right side, the tool should be pulled downwards and on the left side upwards to tighten with a 10 mm wrench.
- 5: The belt should be tightened to approximately 125 kg/229 Hz. To measure this, a special device can be bought at your local BODY BIKE Distributor.

### **Please note:**

**The belt should be equally tightened on both sides.**

**The flywheel should be parallel with the long main side member.**

6: Tighten the counter bolt (2) on both sides of the cycle again.

7: And tighten the bolt(1) again on both sides of the cycle.

8: Close the cycle by fastening the two hatches again.

## REPLACING THE BRAKE BLOCK

The BODY BIKE Synthetic Brake Pad has an expected durability of a minimum of 1500 hours, so eventually the brake pad will be worn.

To ensure that the brake pad is correctly mounted, it has been pre-fitted to the block, and it is only possible to purchase the complete brake block.

To get to the brake block, it is necessary to remove the right side cover from the cycle.

1: Loosen all the screws in the side cover and remove them as well as the bottle holder.

2: Remove the side cover by placing the right pedal arm in the position of 7 o'clock. Then slide the side cover down and left over the pedal arm.



3: Release tension completely on the brake.

4: Remove the two screws holding the brake block to the frame by using an 8 mm wrench, see figure 13.

5: Take the new brake block and fasten it to the frame by tightening the screw closest to the brake block. Then place the block in the correct position under the brake, see figure 14.

6: Fasten the remaining screw furthest away from the block, and then make sure that both screws are tightened properly, see figure 15.

7: Grease should be applied to the cavity on top of the brake block or to the top nut on the brake to ensure a smooth interaction between the two.

8: Finally, remount the side cover by screwing in the corner screws first. Hereafter the remaining screws.

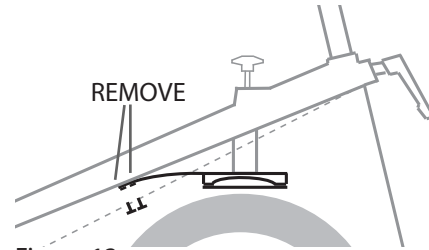

Figure 13

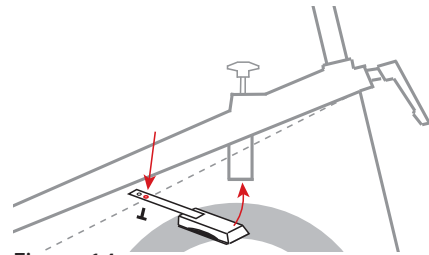

Figure 14

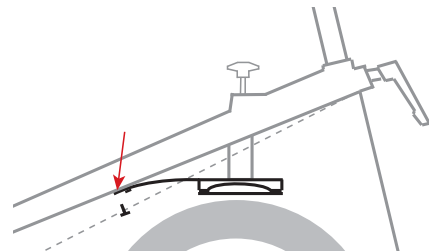

Figure 15

## TROUBLE SHOOTER

How to keep the cycles in good condition?

It is a good idea to place a board at the exit of the spinning room displaying all cycle numbers. Here people can write possible problems or concerns arisen during the exercise. In this way, the people who are servicing the cycles can get up-dated regularly on how the cycles are performing, and problems can be identified before they turn critical.

### INDEX

Adjustment handles	12	Handlebar	8	Rubber feet	5, 8
Adjustment screw	8, 13	Height	4	Saddle	9
Assembly	7- 9	Information, general	5	Side cover	15
Belt	14	Length	4	Tools	2
Bottom frame	5, 8	Maintenance	11-16	Trouble shooter	17
Brake	15	Manufacturer	4	User weight	4
Cleaning	11-13	Mounting	7-9	Wear and tear	5, 17
Cover	15	Patent	4	Weight	4
Crank, warranty	5	Pedal	9	Width	4
Frame	8	Poly V-belt	14, 15	Wheel	8
Grease	12	Post (front and seat)	13		
Handle	8, 9, 12	Product description	4		





## CLASSIC TOOL BOX

Handy tool box containing a wide range of tools for maintenance purposes, e.g. the three spanners included in the starter set. Item number: 92300000



Edition 4

BODY BIKE International A/S  
Pier 6 Nord  
DK-9900 Frederikshavn  
Denmark  
Tlf: +45 9843 9696  
Fax: +45 9843 9688  
[www.body-bike.com](http://www.body-bike.com)